

NEW

EC 960 MODULAR DESIGN

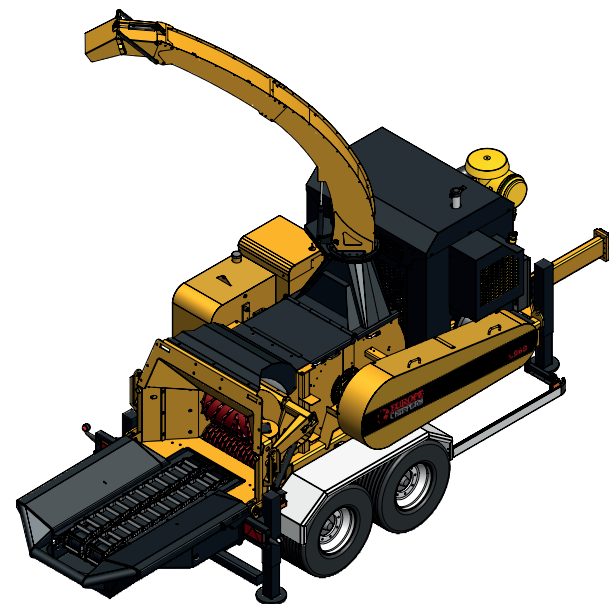

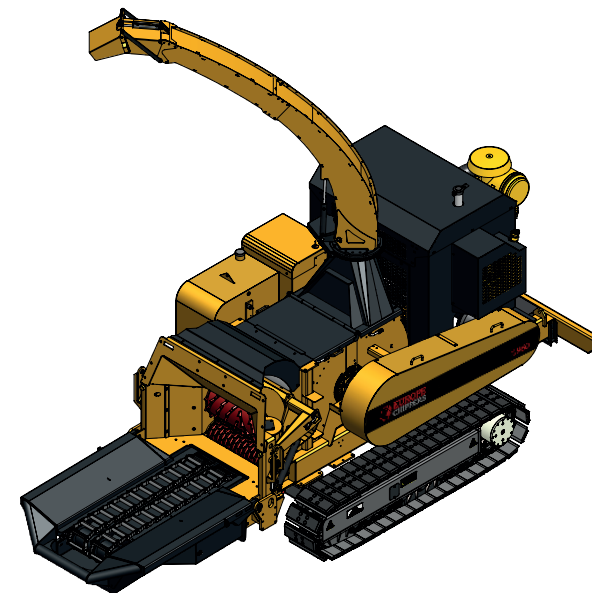

Contents

Base unit	1
Infeed table	2
Power options	3
Crane options	4
Cabin options	5
EC 960 twin axle	6
EC 960 tracks	7

EC 960 BASE UNIT

THE NEW EC 960 EUROPE CHIPPER IS AVAILABLE IN MULTIPLE EDITIONS. EASY CUSTOMIZATION DUE TO SMART MODULAR DESIGN.

Base unit options

- 1 Base unit for EC 960 wood chipper, including:
 - Drum with 3 knives and integrated innovative venturi system for chip discharge.
 - Wide infeed opening (800x600 mm)
 - Automatic no-stress infeed system
 - Hydraulic top infeed roll
 - Hydraulic bottom infeed roll
 - Emergency stop on both sides
 - 50/70 mm screens
 - Solid steel frame module, integrated in the chipper house
 - Replaceable wearplates along the material flow
 - RAL1007 and RAL7021 coating, custom color is optional

The venturi system produces thrust separate from the chipped material and mixes this in the discharge hopper. This reduces the dust production to an absolute minimum and increases chip quality.

- 2 Optional hydraulic vertical siderolls
Vertical siderolls ensure a perfect and more aggressive infeed when chipping material with voluminous branches sticking out.
 - 3 Optional long discharge chute
The long discharge chute can load the chips into even the highest containers up to 5 meters high.
- * Optional Europe Controller
- Programmed PLC
 - Proportional valves
 - Colour display
 - Remote control

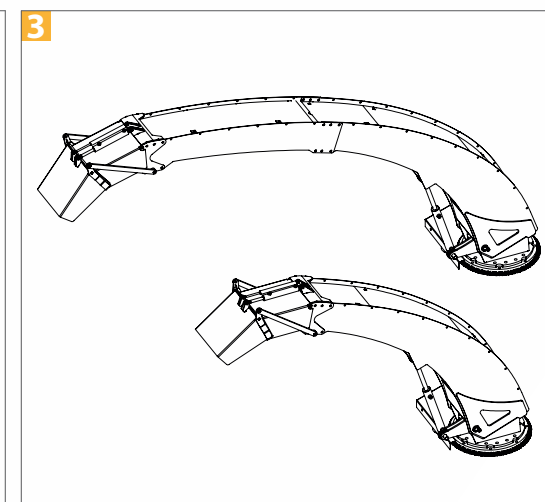
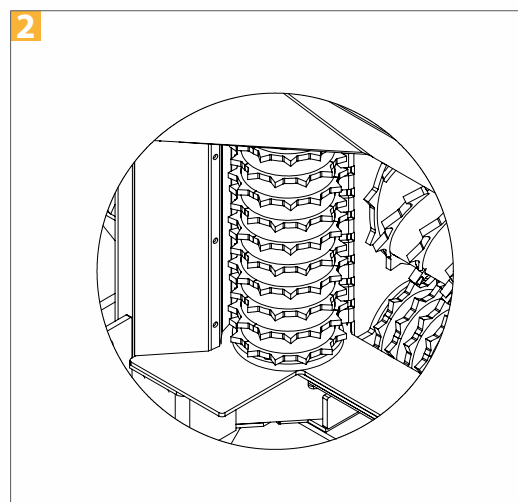
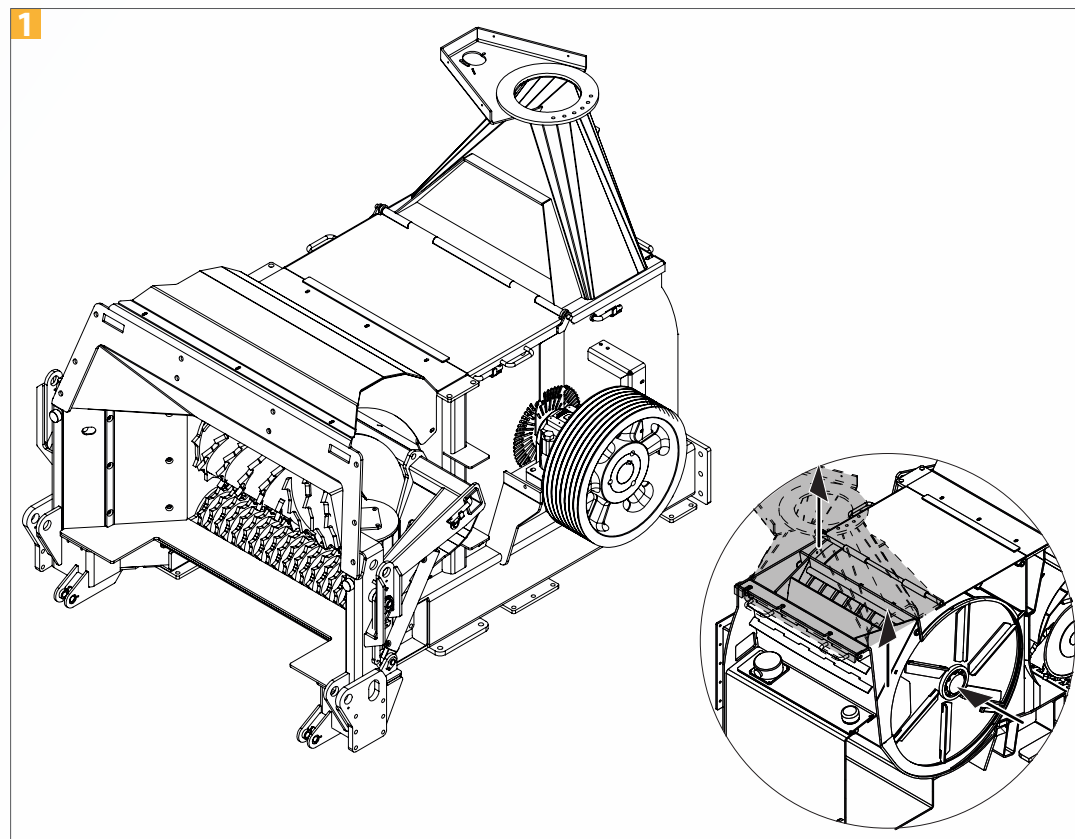
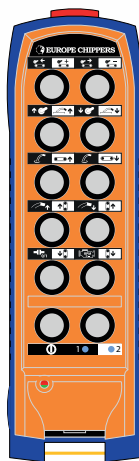

EC 960 INFEED TABLE

THE EC 960 CAN BE CONFIGURED WITH A VARIETY OF INFEED OPTIONS. FROM THE MOST BASIC OPTION TO INDUSTRIAL SOLUTIONS.

Infeed table options

- 1** 90° foldable crane infeed table. The heavy duty crane infeed plate is hydraulically foldable and requires minimal maintenance. The special sand outlet slots guarantee double lifetime of knives and counterknife.
- 2** 90° foldable chain infeed table. The automatic chain infeed makes the infeed process easy and extremely efficient for branches and bushes.
- 3** 180° foldable chain infeed table. This infeed creates the possibility for side-feed and stay within 2,5m width to still be roadlegal.
- 4** The stationary chain infeed table has double the standard length and offers the best choice for industrial purposes, like chipping slabs, logs and brushwood.
- *** The double open infeed chain sorts out sand and rocks and improve lifetime of wearparts inside the chipper.

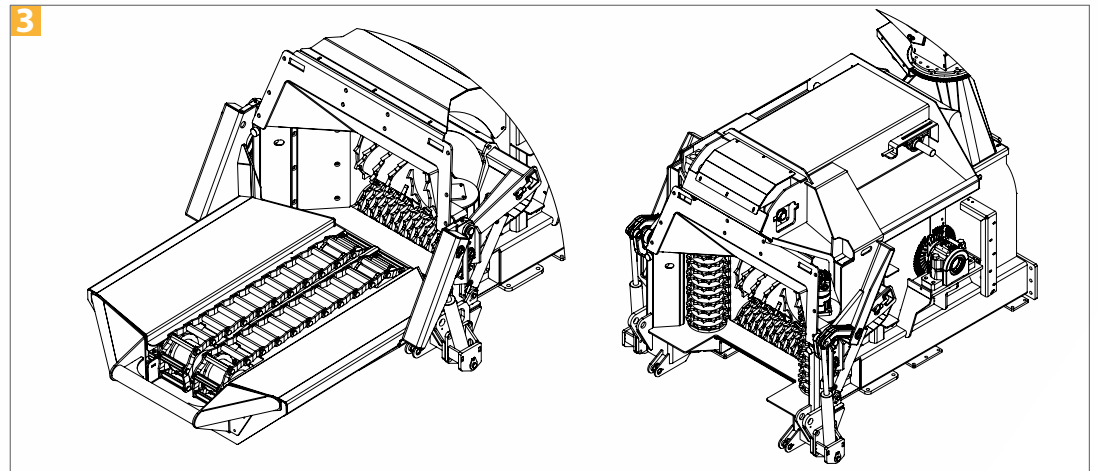
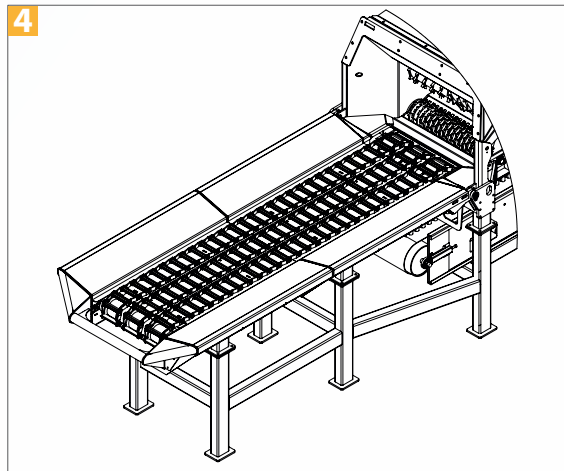
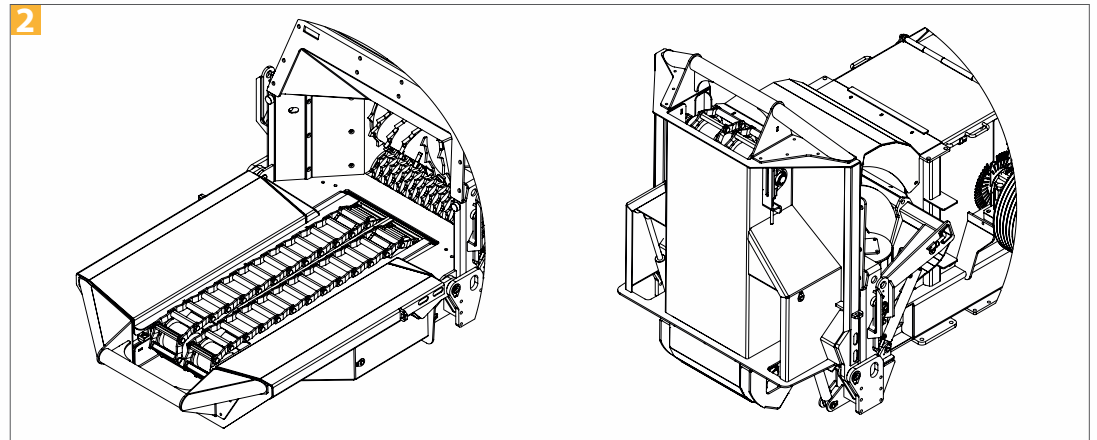
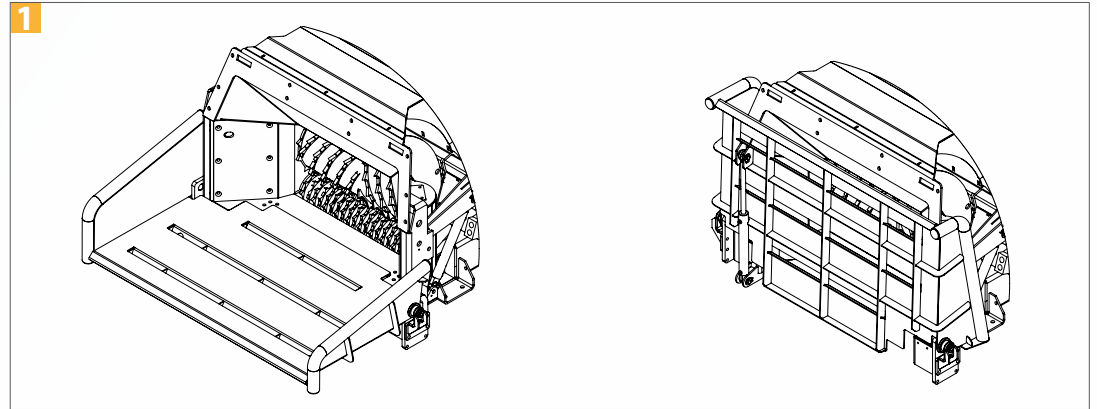

EC 960 POWER OPTIONS

THE EC 960 CAN BE EQUIPPED WITH THE LATEST CATERPILLAR ENGINE, RATED TIER 4 FINAL. THE C7.3 OR C4.4 ENGINES ARE DESIGNED TO MEET THE BEST FUEL EFFICIENCY, LOWEST OPERATING COSTS AND TOUGH EMISSIONS STANDARDS.

Engine options

- 1** Diesel engine drive.
Caterpillar C7.1 Tier 4 Final
6 in-line diesel engine
275 horsepower @ 2000rpm
(l)1804*(w)916*(h)1474
Manual clutch
- 2** Diesel engine drive.
Caterpillar C4.4 Tier 4 Final
4 in-line diesel engine
150 horsepower @ 2200rpm
(l)846*(w)772*(h)868
Manual clutch

Optional a Flexaire reversing fan can be installed, which keeps your radiator clean, maximizes engine performance and saves fuel.

- 3** PTO drive.
This package includes a complete PTO drive configured to the specifications of the customer's tractor. Plug-and-play! Optional, a soft-start function can be added to the drive, this will spare your tractor and provides easy start-up.
- 4** Electro drive.
Electromotors in the range from 90kW up to 200kW can be equipped.
This package includes a powerpack for all hydraulic functions.

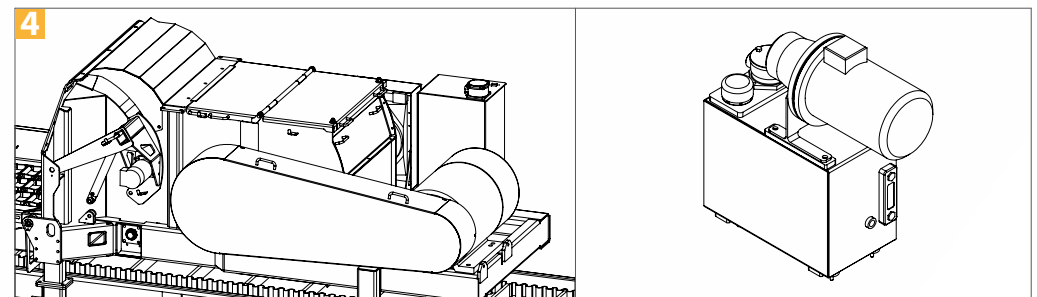
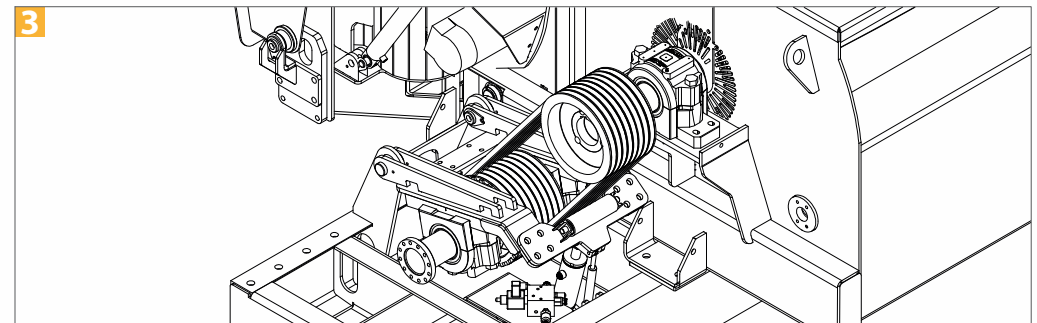
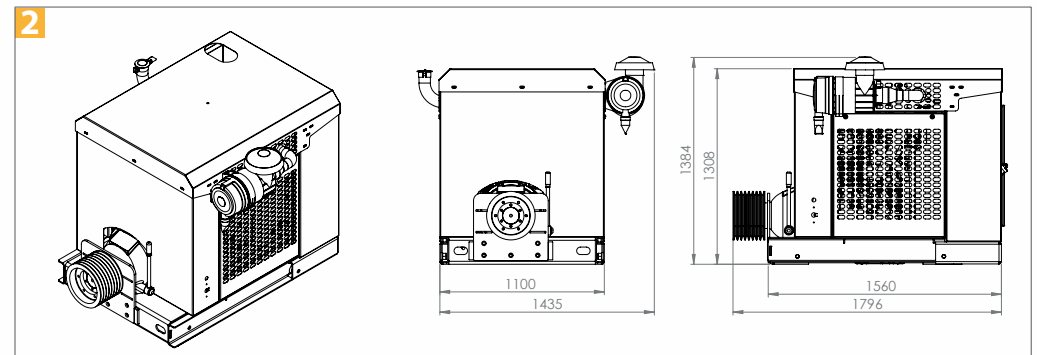
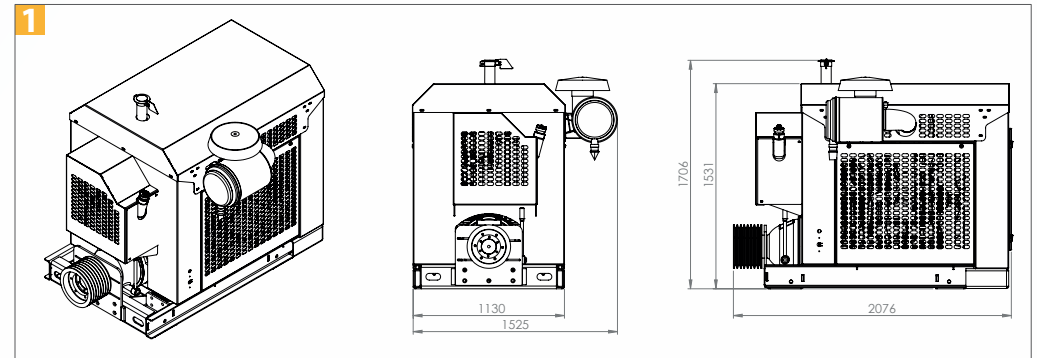

CRANES AND CONTROLLERS

THE EUROPE CHIPPER CAN BE FITTED WITH A CRANE TO YOUR LIKING. WE OFFER SEVERAL BRANDS AND EVERYTHING FROM SMALL TO THE BIGGEST CRANES WITH FULLY EQUIPPED CABINS.

Options for cranes and controllers

- 1** Wide range of Europe Forestry cranes, manufactured by Palfinger and Patruuna. They range from 4 tonnes and outreach of 6.5 meters. up to 10 tonnes and outreach of 9.7 meters.

Two wood grapples are available,
 - Grapple 200 - max opening 1100mm including rotator
 - Grapple 310 - max opening 1500mm including rotator
- 2** Optional crane seat, equipped with safety switch, seat belt and arm rests.
- 3** Optional cabin to comfortably load the Europe Chipper. The cabin can be configured to personal preferences. See page 4.2 for cabin options.
- 4** Mechanical control. In the basic valve system, the extension, the grapple and the support legs are controlled with independent control levers.
- 5** Ergo control. The loader operations are controlled with three-function ERGO levers. The extension and the grapple are used by modifying the position of the wrist.
- 6** Electronic pilot control. High-quality Danfoss PVG32 valves with extended Profi 1 handles provide 6 proportional functionalities.
- *** The machine is equipped with 9-tonnes support legs to keep stability while working. The number and position of the support legs depends on the build-up of the machine.

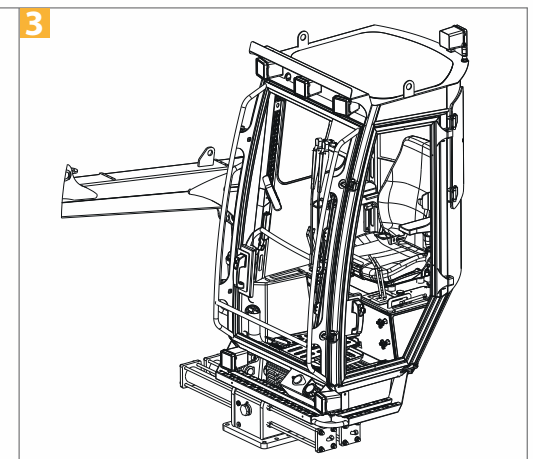
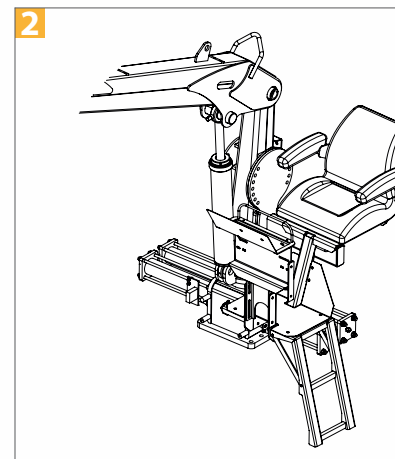
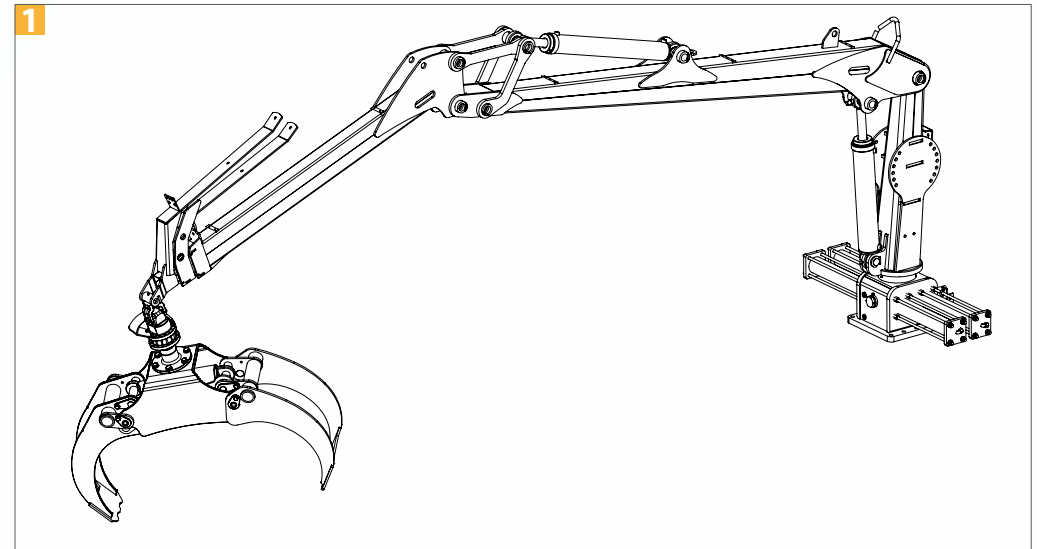

FORESTRY CABIN OPTIONS

THE EUROPE FORESTRY CRANE CAN BE EQUIPPED WITH A COMFORTABLE CABIN WITH MULTIPLE OPTIONS.

Options for cabin

- 1** Standard specification:
 - High-strength lightweight aluminium construction
 - Seat with high backrest and seat heating
 - Radio, CD, MP3-player with bluetooth including 2 speakers
 - Control panel with switches
 - Hardened glass windows (optional 10mm polycarbonate)
 - Windshield wiper and washer
 - LED interior lighting
 - PVC interint lining
 - Prepared for 8 working lights
- 2** Integrated lifting unit and lock valve, lifting height is 1100mm. Cylinder with both end damping.
- 3** Up to 8 pieces of work lights can be installed, choose from:
 - H3 (750 lumen)
 - Xenon (1300 lumen)
 - LED (1800 lumen)
- 4** Several cooler and AC options available.
- 5** Cabin heating either by a heater using diesel fuel or a heat exchanger connected to the carrier coolant system.
- 6** Cabin can be mounted on the Europe Chipper in combination with four 9-tonnes hydraulic support legs to stabilize the machine. The cabin can be rotated for transport, so the machine stays within 4 meters height and is therefore roadlegal.



EC 960 TWIN AXLE

THE EC 960 IS THE NEW MIDDLE MODEL FROM THE EUROPE CHIPPERS LINE-UP. EASY TO OPERATE, MAINTAIN AND MANEUVER. THE TWIN AXLE VERSION IS TESTED AND APPROVED FOR UP TO 80 KMH.

EC 960 details

- 1** The automatic chain infeed table makes the infeed process easy and extremely efficient. With the open infeed chain you sort out sand and rocks and improve lifetime of wearparts inside the chipper.
- 2** The long discharge chute makes it possible to load every container up to 5 meters high.
- 3** The EC960 is equipped with a Caterpillar C7.1 Tier 4 Final engine. This 275 horsepower engine delivers enough power to generate a production capacity of 120 m³/h.
- 4** The twin axle version of the EC 960 comes standard with one support leg, lateral protection, air brakes and an 38mm draw bar.
Optional German TÜV certificate and 50mm draw bar.

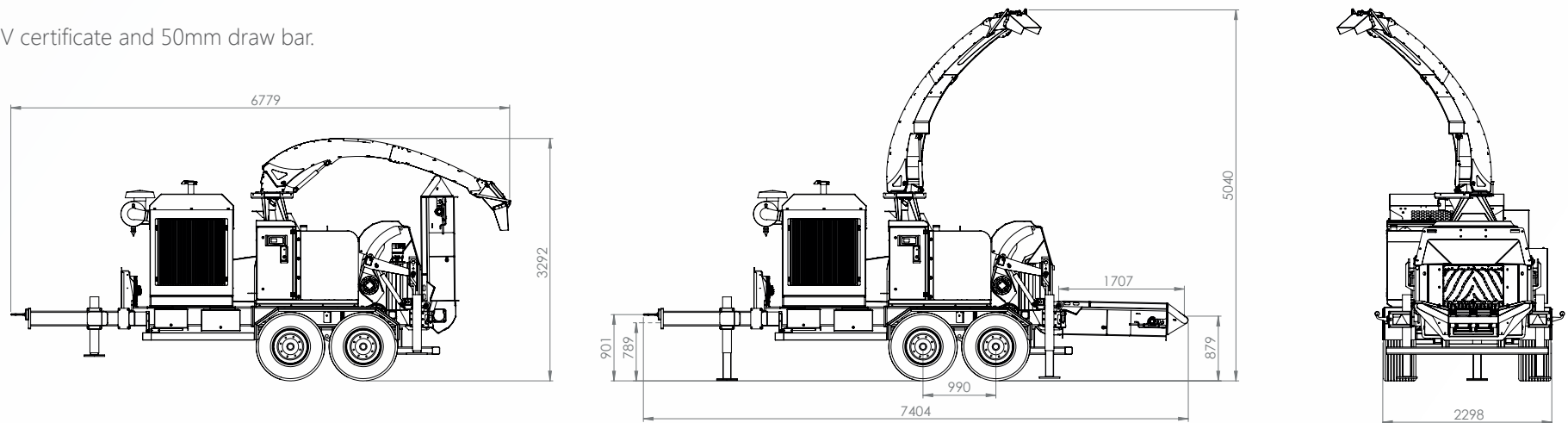
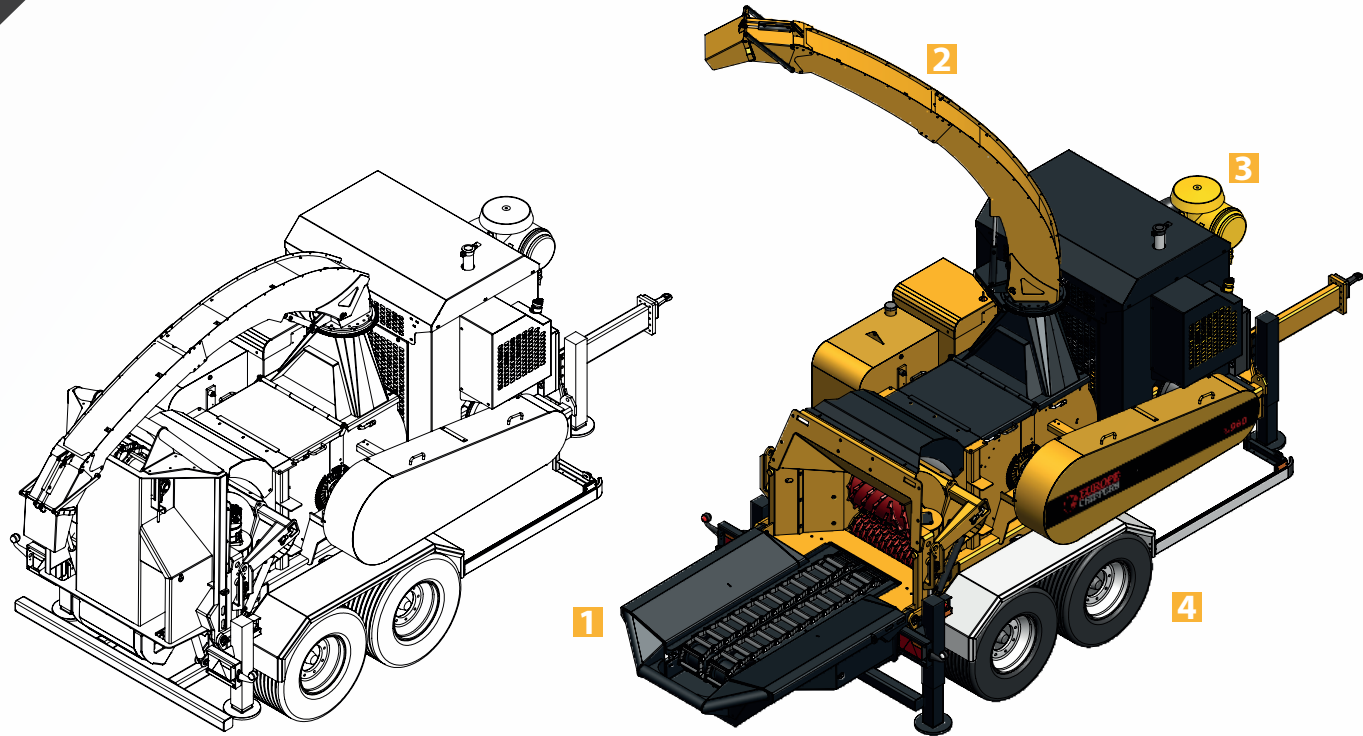

EC 960 TRACKS

THE EC 960 IS THE NEW MIDDLE MODEL FROM THE EUROPE CHIPPERS LINE-UP. EASY TO OPERATE, MAINTAIN AND MANEUVER. THIS VERSION IS FITTED WITH 400MM WIDE TRACKS FOR THE MOST RUGGED TERRAIN.

EC 960 details

- 1 The standard steel tracks can be fitted with rubber pads for maneuvering on concrete floors without damage. Controlling the tracks can be done by remote control.

With an electronic valve the tracks switch between the low- and high gearing.

- 2 Total weight of this machine is only 9500kg and compact enough to fit in a container.

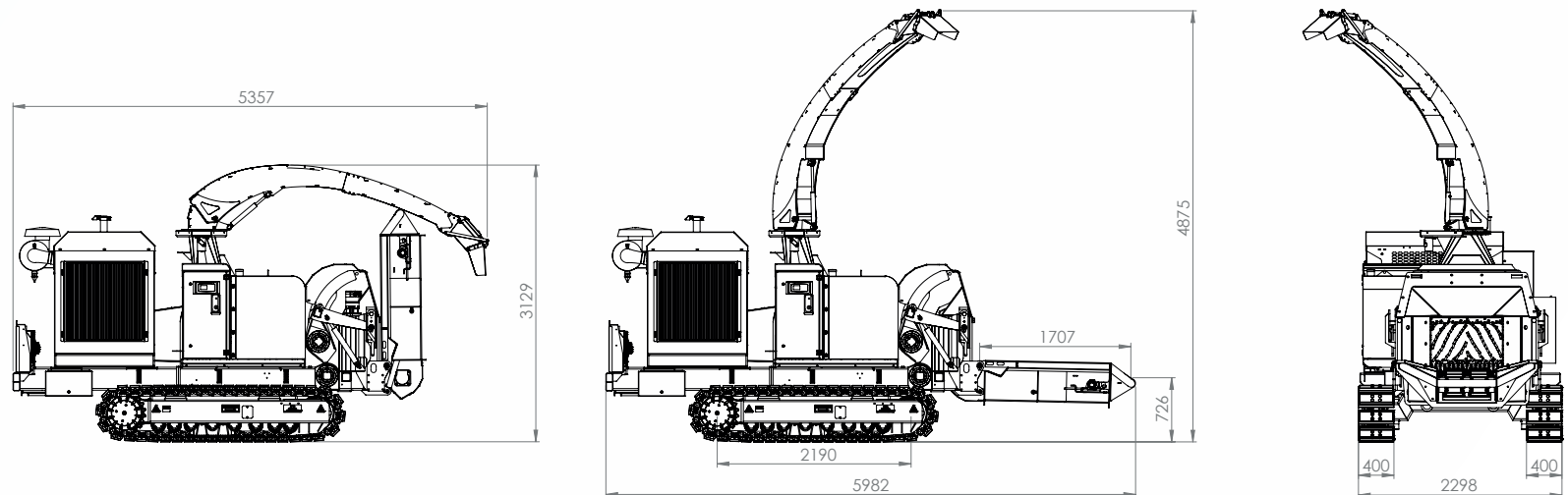
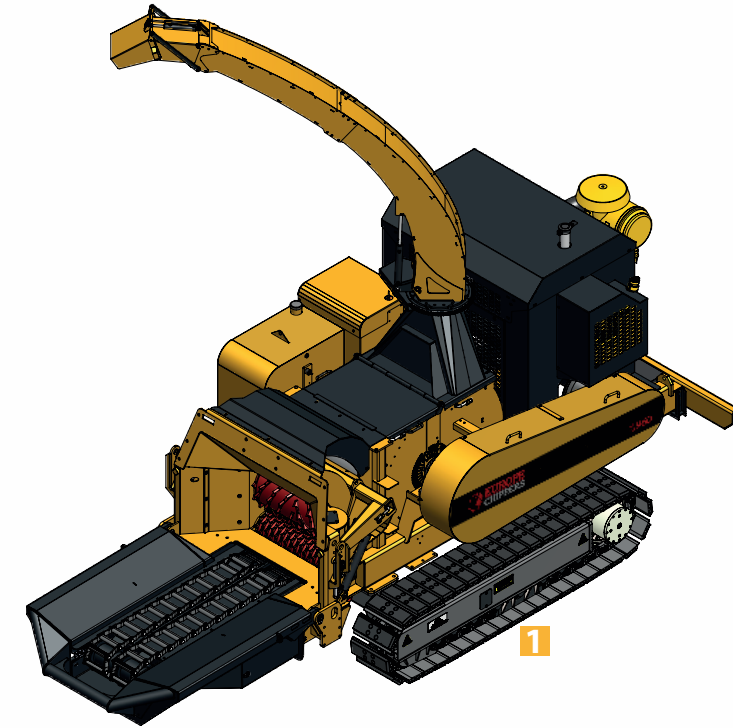
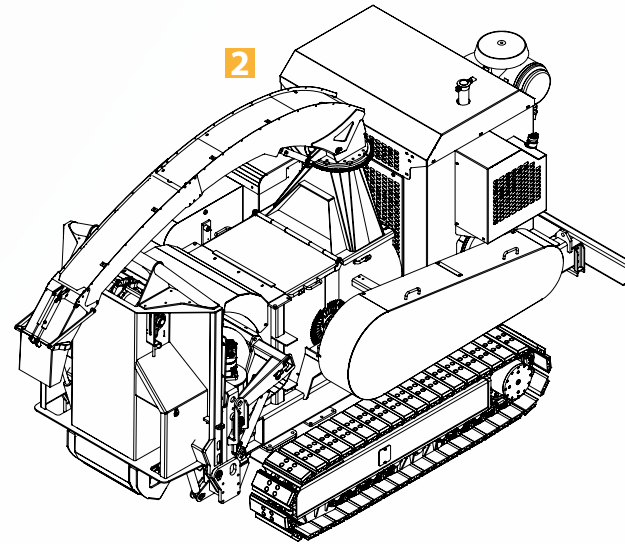

DEALER

--

